



# VGA CMOS Image Sensor

**BF3903**

**Datasheet**

Only for BYD Customer



# 1. General Description

The BF3903 is a highly integrated VGA camera chip which includes CMOS image sensor (CIS) and image signal processing function (ISP). It is fabricated with the world's most advanced CMOS image sensor process to realize ultra-low dark noise, high sensitivity and very low power imaging system. The sensor consists of a 648 x 488 effective pixel array which has an optical format of 1/11 inch. It has integrated noise canceling CDS (Correlated Double Sampling) circuits, analog global gain and separated R/G/B gain controller, auto black level compensation and on-chip 10-bit ADC. The on-chip ISP provides a very smooth AE (Auto Exposure) and accurate AWB (Auto White Balance) control. It provides various data formats, such as Bayer RGB, RGB444, RGB555, RGB565, YCBCR 4:2:2. It has a commonly used two-wire serial interface for host to control the operation of the whole sensor.

The product is capable of operating at up to 30 frames per second at 24MHz clock in VGA mode, with complete user control over image quality and data formatting. All required image processing functions, including exposure control, white balance control, color saturation control and so on, are also programmable through the two-wire serial bus.

## 2. Features

- Standard optical format of 1/11 inch.
- 30 frame/sec VGA mode @ 24MHz master clock.
- Ultra-low dark noise at high temperature.
- Various output formats: YCBCR4:2:2, RGB444, RGB555, RGB565, Raw Bayer(648 x 488).
- Power supply: 2.7~3.1V for analog, 1.7~3.1V for I/O.
- Horizontal /Vertical mirror.
- 50/60Hz flicker cancellation.
- Programmable I/O drive capability.
- Automatic black level control.
- Image processing function: Lens Shading Correction, Gamma Correction, Bad pixel correction, Color Interpolation, False Color Suppression, Purple Fringe Correction, Low Pass Filter, Color Space Conversion, Color Correction, Edge Enhancement, Auto exposure, Auto White Balance, Color Saturation and Contrast, and Data Format Conversion.
- 12 types of special video effect
- On-chip test pattern generation of many types including customer programmable
- Package: CSP, Bare Die



### 3. Applications

- Cellular Phone Cameras
- Notebook and desktop PC cameras
- PDAs
- Toys
- Digital still cameras and camcorders
- Video telephony and conferencing equipments
- Security systems
- Industrial and environmental systems

### 4. Technical Specifications

- Active pixel array: 648 x 488
- Pixel size: 2.0 $\mu$ m $\times$ 2.0 $\mu$ m
- Sensitivity: 1.0V/lux.s
- Dark current: 3 mV/S at 40 $^{\circ}$ C
- Power consumption: 56mW @ 30fps and single 2.8V supply
- Standby current: Typical 30uA
- S/N Ratio: 45dB
- Dynamic range: 56dB
- Operating temperature: -20~60 $^{\circ}$ C
- Stable Image temperature 0~50 $^{\circ}$ C
- Optimal lens chief ray angle: 25 $^{\circ}$

## 5. Functional Overview

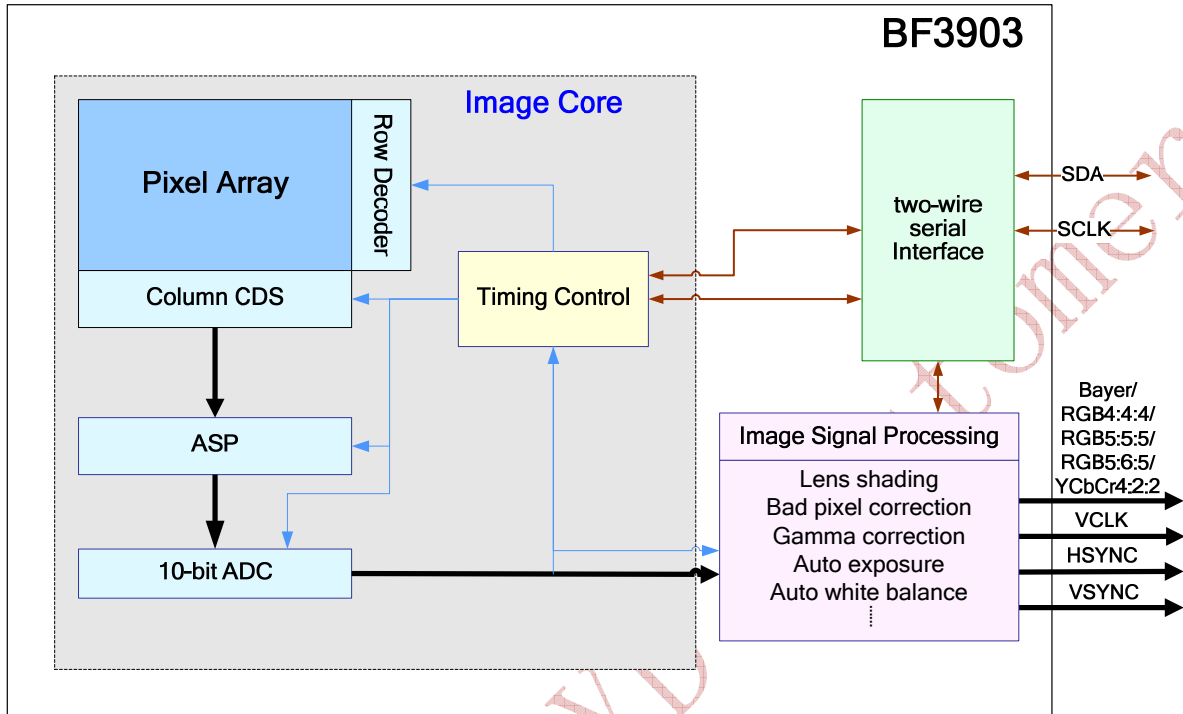

Figure 1. Block Diagram

BF3903 has an active image array of 648x488 pixels. The active pixels are read out progressively through column/row driver circuits. In order to reduce fixed pattern noise, CDS circuits are adopted. The ASP block is mainly used to control global gain and color gains to get accurate exposure and white balance under different light condition and color temperature. The analog signal is transferred to digital signal by A/D converter. The digital signals are processed in the ISP Block, including Bayer interpolation, low pass filter, color correction, gamma correction, data format conversion and so on. Users can easily control these functions via two-wire serial interface bus.



## RESTRICTIONS ON PRODUCT USE

- The information contained herein is subject to change without notice.
- BYD Microelectronics Co., Ltd. (short for BME) exerts the greatest possible effort to ensure high quality and reliability. Nevertheless, semiconductor devices in general can malfunction or fail due to their inherent electrical sensitivity and vulnerability to physical stress. It is the responsibility of the buyer, when utilizing BME products, to comply with the standards of safety in making a safe design for the entire system, including redundancy, fire-prevention measures, and malfunction prevention, to prevent any accidents, fires, or community damage that may ensue. In developing your designs, please ensure that BME products are used within specified operating ranges as set forth in the most recent BME products specifications.
- The BME products listed in this document are intended for usage in general electronics applications (computer, personal equipment, office equipment, measuring equipment, industrial robotics, domestic appliances, etc.). These BME products are neither intended nor warranted for usage in equipment that requires extraordinarily high quality and/or reliability or a malfunction or failure of which may cause loss of human life or bodily injury ("Unintended Usage"). Unintended Usage include atomic energy control instruments, airplane or spaceship instruments, transportation instruments, traffic signal instruments, combustion control instruments, medical instruments, all types of safety devices, etc.. Unintended Usage of BME products listed in this document shall be made at the customer's own risk.

Only for BYD